

- NOTES:
1. APPLY LOW STRENGTH THREAD LOCKER TO THREADS. TIGHTEN TO 80 IN-LBS TORQUE.
  2. INSTALL ROTOR WITH DIMPLE FACING NOTCH IN TOP BODY.
  3. INSTALL BALL AND SPRING INTO INDICATED LOCATION.
  4. USE EXTREME CAUTION. DO NOT DAMAGE BOTTOM SURFACE OF ROTOR OR TOP SURFACES OF POPPETS.
  5. REASSEMBLE UPPER SECTION OF VALVE FIRST.
  6. PLACE ITEMS 3, 4, 7, 12, AND 17 IN BASE AND FINISHED ASSEMBLY
  7. STRETCH O-RING OVER 87114015 AFTER IT HAS BEEN ATTACHED TO THE ROTOR.

NO	QTY	PART NO	DESCRIPTION	STD SEAL KIT	FKM SEAL KIT	SPRING KIT
1	1	21410047	SCREW, CAP, SOCH, 10-24 X 3/8, ALY			
2	4	21410100	SCREW, CAP, SOCH, 10-24x3/4, ALY			
3	3	21430049	WASHER			X
4	3	23350138	SPRING, COMPRESSION			X
5	1	23350139	SPRING, COMPRESSION			
6	1	23650019	BALL, .1875, 304 SSTL			
7	3	39000038	O-RING, (-008)	X	39051021	X
8	1	39001024	O-RING, (-121)	X	39051008	
9	1	39050043	O-RING, (-012)	X	39V51044	
10	1	39051055	O-RING, (-021)	X	39001049	
11	1	39054010	BU RING, (-012)	X	39V54010	
12	1	85600902	HANDLE, VALVE, LONG			
13	1	85600903	HANDLE, VALVE, SHORT			
14	1	85600904	SCREW, ADAPTER, HANDLE, VALVE			
15	1	87114002	BODY, VALVE, MANUAL			
16	1	87114008	WASHER, THRUST, VALVE, MANUAL			
17	1	87114009	BEARING, THRUST, NEEDLE, VALVE, MANUAL			
18	1	87114012	BASE, VALVE, MANUAL, SAE 4			
19	1	87114013	NUT, MOUNT, PANEL, VALVE, MANUAL			
20	1	87114015	ADAPTER, HANDLE, VALVE			
21	2	90199924	PIN, DOWEL, 1/8 X 3/8, STD, STL, HDN			
22	1	90199984	PIN, DOWEL, 4mm x 14mm, ALY, HDN			
23	3	39F54019	BU RING, (-008)	X	39V54015	X
N/A	N/A	60701614	KIT, SEAL, VALVE, MANUAL	NOTED	N/A	N/A
N/A	N/A	60701615	KIT, SEAL, FKM, VALVE, MANUAL	N/A	NOTED	N/A
N/A	N/A	61701000	KIT, SPRING, VALVE, MANUAL	N/A	N/A	NOTED
N/A	N/A	IS7125	INSTRUCTION SHEET			

## PARTS LIST



VEKTEK, INC.  
1334 E. SIXTH AVE. P.O. BOX 625  
EMPORIA, KS. 66801 U.S.A.

---

ASSEMBLIES AFFECTED  
71-3474-01

PARTS LIST, ASSY, VALVE, MANUAL, SAE 4, 4/13, PBC

---

SIZE A PL7197

REV D

D	4153	RELEASE	JDW	06/18/20
REV	IN ACCORDANCE WITH ECN	EFFECTIVE DATE	REVISED BY	DATE
DRW BY:	ALS	DRAWING STATUS: <b>Released</b> PRODUCTION APPROVED FOR RELEASED STATUS ONLY		
DATE:	03/22/19			

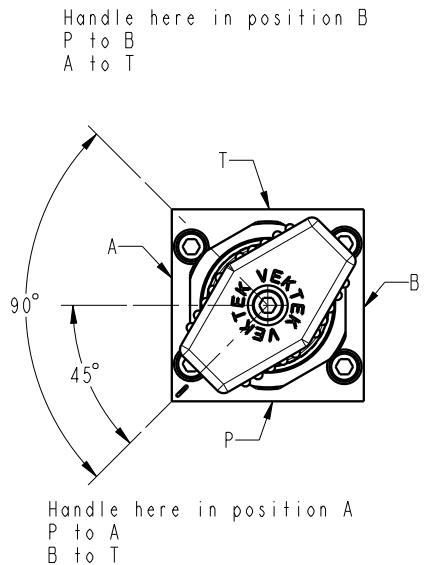
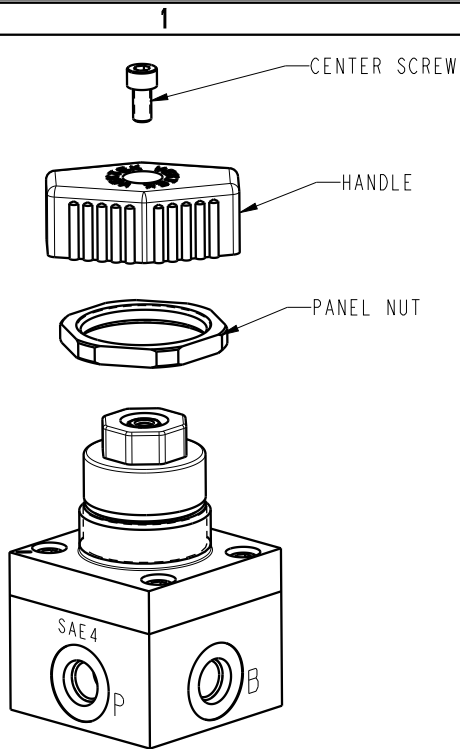

Center Position  
A and B dump  
to tank

P-Blocked Center Valve to be used with  
double acting systems using a pallet decoupler

To Reposition Handle:

1. Remove center screw
2. Take off and reposition handle
3. Apply low strength loctite to center screw
4. Torque center screw to 20 in-lbs

To Panel Mount Valve:

1. Remove center screw
2. Take off handle and panel nut
3. Position valve in panel and tighten panel nut
4. Replace handle
5. Apply low strength loctite to screw and torque to 20 in-lbs

OR

1. Use screw holes in bottom of base to mount valve.  
(metric uses M5x0.8 and inch uses 10-24 bolts)

<b>INSTALLATION INSTRUCTIONS</b>		 <b>VEKTEK</b> VEKTEK, INC. 1334 E. SIXTH AVE. P.O. BOX 625 EMPORIA, KS. 66801 U.S.A.	
		INSTRUCTION SHEET, VALVE, HNL, PANEL MNT, 3/4, PBC	
ASSEMBLIES AFFECTED		SIZE	REV
71-3474-01		A	A
43-1347-41		<b>1S7125</b>	

A	3892	RELEASE	ALS	08/08/19
REV	IN ACCORDANCE WITH ECN	EFFECTIVE DATE	REVISED BY	DATE
DRW BY:	ALS	<b>DRAWING STATUS: Released</b> PRODUCTION APPROVED FOR RELEASED STATUS ONLY		
DATE:	08/08/19			